

**AGD**<sup>®</sup>  
AUSTRALASIA

SAFER  
GREENER  
MORE EFFICIENT



PRODUCT MANUAL

**AGD**

# Sivard System

Temporary loop replacement  
system

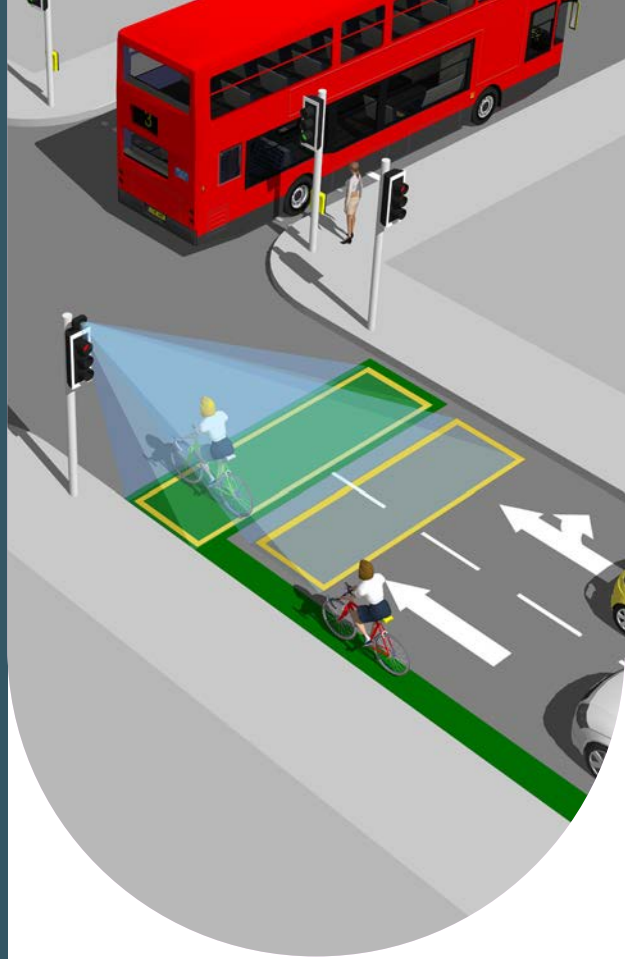

# TABLE OF CONTENTS

<b>INTRODUCTION</b>	<b>3</b>
Product Overview and technology	3
Key features	3
Typical applications	3
Product overview image AGD650	4
Product overview image LE4	5
Product overview image PS645	5
<b>PRODUCT COMPONENTS</b>	<b>6</b>
<b>INSTALLATION AND COMMISSIONING</b>	<b>7</b>
Physical Installation	7
Step 1 – Typical mounting post	7
Step 2 – RLI	7
Electrical Installation	8
Set-up AGD RLI-4	9
Set-up AGD650	15
Connecting	16
Connectinf Wi-fi	16
Connecting device	16
Set-up device using Wifi AGD Touch-setup	17
Step 1 – Name site	17
Step 2 – Set zones	18
Step 3 – Choose settings	21
Example image 1	22
Example image 2	23

<b>TESTING AND COMMISSIONING</b>	<b>24</b>
<b>IMPORTANT SAFETY INFORMATION</b>	<b>25</b>
Safety Precautions	25
<b>DISCLAIMER</b>	<b>27</b>
Warranty	27
Contact Details	27



**AGD TOUCH**

WiFi 3-Click Setup

# INTRODUCTION

The Sivard System is a self-contained temporary loop replacement system. Using the proven AGD Systems 650 stop line detector and incorporating a radio link back to the traffic signal controller to a four-channel loop emulator. The system is designed specifically for the Australian/ New Zealand road network. The Sivard System is easy to install, simple to set up and remove, making it suitable for short to long-term deployment to maintain critical loop functions. The system comes in a hard case making it suitable to be transported in work vehicles.

# KEY FEATURES

- Two configurable detection zones
- SCATS compatible detection zones
- Design to be installed on current traffic signal posts and hardware
- Utilises existing field wiring
- No special cabling required
- Wireless encryption, 128-bit AES encryption
- Anti-collision software in wireless modules
- Auto channel hopping, Max 10 channels
- Configurable PAN ID (network ID)
- Handshaking, Done at module transmission level, transmits on input change, and also every 10 seconds if no change.
- If no updates for Remote device for more than 30 seconds associated outputs will default to on and status updated to Not connected on LCD
- No requirement to remap inputs to controller, as the signal for the detector is manipulated to simulate an inductive loop.

# Sivard System

Temporary loop replacement system

# TYPICAL APPLICATIONS



Dual Zone / Active Travel (Cycle Lane Detection)

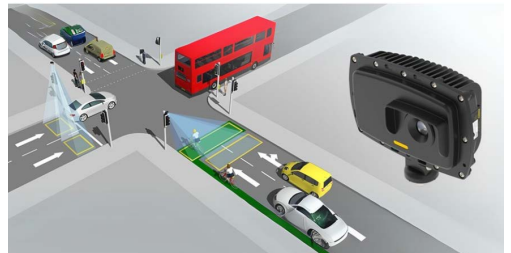

Dual Zone / Multi lane Advance Stop-line (cycle refuge area)

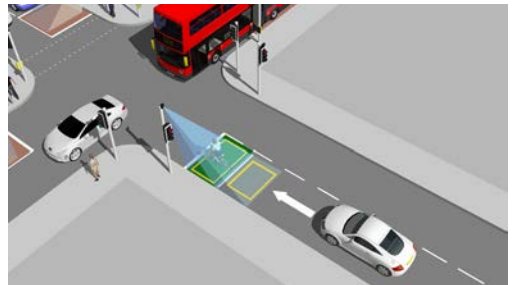

# INTRODUCTION

## PRODUCT OVERVIEW IMAGE

Sivard System

Temporary loop replacement system

AGD650



# INTRODUCTION

## PRODUCT OVERVIEW IMAGE

# Sivard System

Temporary loop replacement system

## RLI



## PMI



## PRODUCT COMPONENTS

AGD650-400-022: Two channel, Stop line detector

PMI-4: Pole mounted four channel power supply/ transmitter

RLI-4: Four channel receiver, loop emulator

Hard case

**Sivard System**

Temporary loop replacement system



# PHYSICAL INSTALLATION

Sivard System

Temporary loop replacement system

## PMI and AGD650

Mount the PMI and AGD650 on a suitable mounting point on a traffic signal post.

## TYPICAL POST MOUNTING



## RLI:

The RLI sits on the shelf in the traffic signal controller

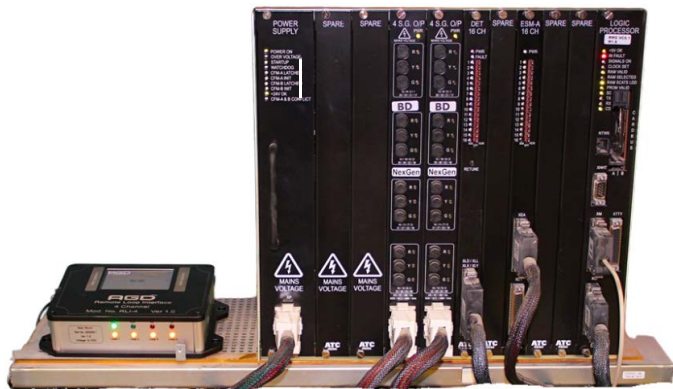

### POWER UP SEQUENCE

**AGD650:** Plug the AGD650 into the plug socket on the base of the PMI.

**PMI :** Enclose the cables in supplied flexible conduit and secure the flexible conduit under the conduit clamp on the post top mounting assembly

#### Connect the cables as shown below

Pin No.	Wire Colour	Function	Connection
1	Red	240V positive	Permanent 240V Supply
2	Black	240V negative	Permanent 240V Negative
3	Green/Yellow	Earth/Ground	Post Earth

**RLI :** Plug and secure green terminal block from the power pack into power connection terminal block on the back of the RLI unit. Plug the power pack into the GPO in the traffic signal controller.

Connect RLI channel outputs and loop termination board in the traffic signal controller using the supplied twisted pair cable.

#### Connect the cables as shown below

Wire Colour	RLI	Loop Connection Board
Red Pair	Channel One	Designated Loop Terminal
White Pair	Channel Two	Designated Loop Terminal
Black Pair	Channel Three	Future Use
Blue Pair	Channel Four	Future Use

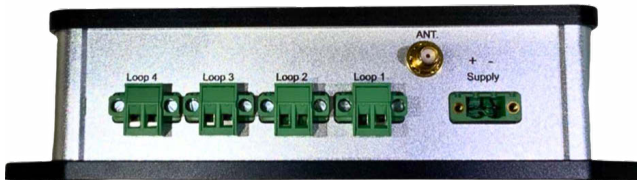

### Antenna

Connect supplied Blade Antenna to the "Ant" plug on the back of the RLI. If the signal is too low, A low-profile Antenna is also provided with 1m cable and SMA connector to connect to the RLI-4 unit, this controller cabinet will require a hole to mount the antenna

## SET-UP AGD RLI-4

### 1 - Password

On power up or screen wake when touched, the screen will show:

Touch the text box and a keypad will appear. Enter the PIN number. If correct the screen will change to the monitor screen, else repeat.

Note: each unit has an individual pin number for security purposes

Text box to enter PIN number



SET-UP AGD RLI-4

2 - Monitor Screen



3- Change Device ID and channel numbers

Touch Dev ID or Ch No. textbox to enter the remote device or channel number required, leave zero if not used.

A keypad will appear to enter the number, as per image on left

Note: each loop output can be allocated to a specific remote device and specific input on the remote device

## SET-UP AGD RLI-4

## 4-Change Site number

By touching the top Net ID textbox, a different screen will appear showing site ID input.

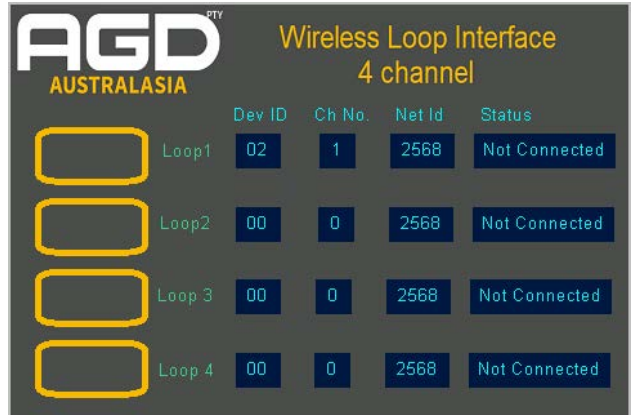

Touch Site number textbox and a keypad will appear, as shown on the left. Enter site number as shown and press OK.

Now, select Save to write information to memory or cancel to return without saving.

*Note:* Enter the Traffic signal site number or asset number into the detectors and the RLI-4 interface, this reconfigures the wireless module to different PAN ID to avoid close sites interfering with each other.

If the site number has changed, the number in the PMI will also need to be changed using the supplied software connected to the USB port on the PMI



## SET-UP AGD RLI-4

## 5- Loop monitoring and testing

Now that the system is setup, when remote device is powered the status box will show "Connected".

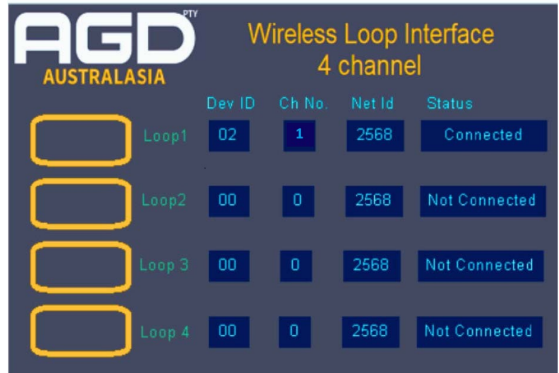

	Dev ID	Ch No.	Net Id	Status
Loop1	02	1	2568	Connected
Loop2	00	0	2568	Not Connected
Loop 3	00	0	2568	Not Connected
Loop 4	00	0	2568	Not Connected

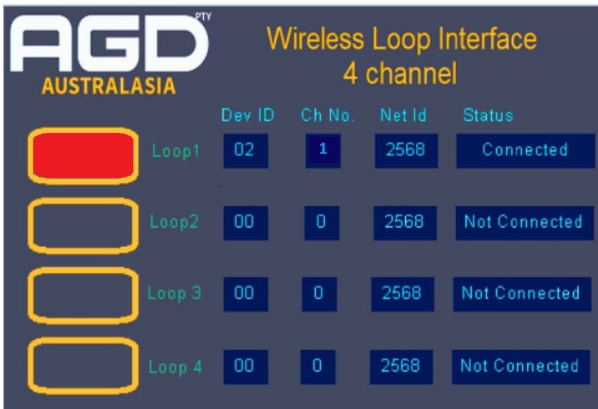

	Dev ID	Ch No.	Net Id	Status
Loop1	02	1	2568	Connected
Loop2	00	0	2568	Not Connected
Loop 3	00	0	2568	Not Connected
Loop 4	00	0	2568	Not Connected

If device No. 02, channel 1 detects a vehicle, then the loop image for this device will change to Red (detect mode) as shown on left.

**Note:** The output connections to the controller can be tested by pressing the image of the loop, this will be same as receiving a trigger from remote device.

## SET-UP AGD RLI-4

### 6 - Indicators

PWR: Power indicator should be on when power connected to unit.

Run: The run indicator should be flashing at a 1hz rate to indicate MCU operating.

Rx: Flashes when data received from remote device.

Tx: TX operates when in configuration mode and RSSI mode only

Loop1status

Loop2status

Loop3status

Loop4status

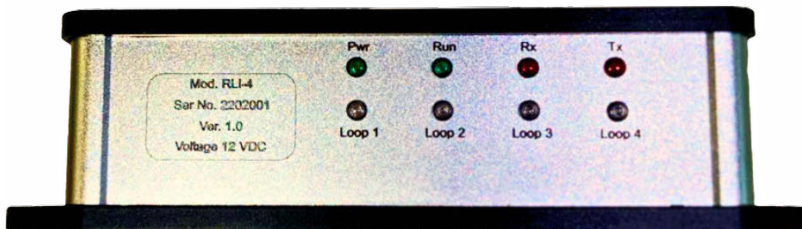

## SET-UP AGD RLI-4

## 7 - Signal strength test

To test the signal strength from the PMI, place the RLI into test mode by entering the radio test pin number into the keypad. The pin number can be found on the inside of the hard case.



Push the reset button and reset the screen. Close the controller cabinet door for 30 seconds to a minute. Open the cabinet door and check the signal strength. The signal strength should be between 40-db and 95-db. If the reading is higher than 95-db, fit the "Puck" external antenna. Retest the signal

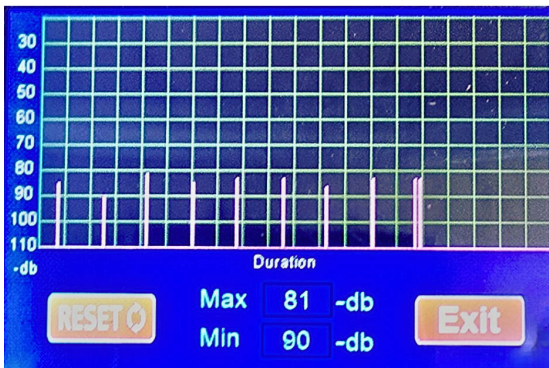

# INSTALLATION AND COMMISSIONING

## AGD650 SETUP

### STEP 1 – MOUNTING HEIGHT

The Dual Zone Stop-line Detector has excellent performance when mounted between heights of 3–6 metres.

If you have an application whereby you wish to mount the detector outside of these heights, then please contact AGD.

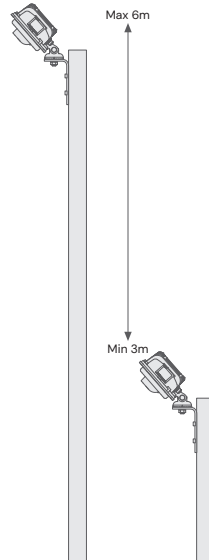

**Sivard System**

Temporary loop replacement system

### STEP 2 – DETECTOR ALIGNMENT

The AGD650 Dual Zone Stop-line Detector should be mounted using the supplied hardware. The optimal mounting angle will change depending on the installation location; aiming the camera to the centre of the area of interest is a good start position. The mounting angle may need to be corrected during commissioning stage of the installation. Ensure the detector is securely fixed and the mounting nut is tight.

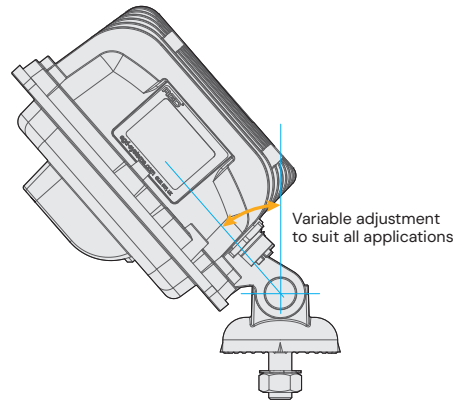

### STEP 3 – FINAL ADJUSTMENT & VERIFICATION

Confirm the detector is correctly aligned. The entire stop-line should be visible when looking at the detector's live view within the GUI. Where possible, the field of view should include at least one full vehicle length before and after each detection zone. The horizon should be out of view to reduce sun glare. Once complete, please monitor traffic to ensure zones are correctly placed.



## CONNECTING

The AGD 650 Dual Zone Stop-line Detector has been designed with efficiency and ease of use in mind. It can be set up simply by connecting to it by WiFi and using a browser window. No additional software needs to be installed.

This step-through process describes the actions required to set up the detector upon initial deployment when first removed from the box.

### CONNECTING WIFI

Check the red LED has illuminated and flashed 5 times on the rear of the unit. Search for the unit and identify it by its **serial number (S/N)**:

**650:XXXXXX-XXXX-TBD** (the 'X's denote the S/N, TBD is a renameable field used to name the pole location the 650 is installed on)

Click 'connect' and input the **default password**:

**Agd650:XXXXXX-XXXX** (the 'X's denote the S/N)

**For security reasons, AGD Systems strongly recommends changing the password during step 1 of the set-up process.**

Please note that, if the password is changed and the new password is lost, the product will need to be returned to AGD to be reset.

The LED on the underside of the unit should now be illuminated blue to show WiFi is successfully connected and your device should show connected.

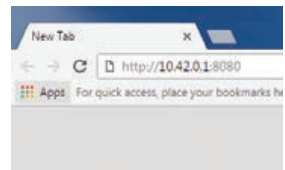
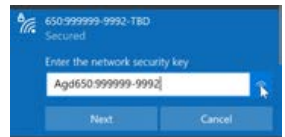
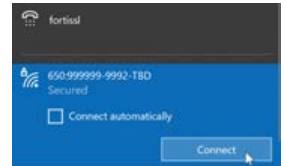

### CONNECTING DEVICE

Complete Wifi connection step as above.

Launch a browser on your smartphone, tablet or laptop (Modern versions of Google Chrome, Safari, Firefox and Microsoft Edge are all supported).

In the address bar of your browser, enter the 'IP Address':

**http://10.42.0.1:8080**

You will be presented with your initial AGD Touch-setup page.

### SET-UP DEVICE USING AGD TOUCH-SETUP

When logged in to the device for the first time you are presented with the set-up screen. This is the AGD Touch-Setup, a three stage process that allows installers to configure the device quickly and efficiently.

#### STEP 1 – NAME SITE

The screenshot shows the AGD 650 Dual Zone Stop-Line Detector setup interface. At the top, there is a navigation bar with 'HOME', 'SETUP', and 'ADVANCED' tabs. Below this, a progress indicator shows three steps: '(1) Site/WiFi Settings', '(2) Set Zones', and '(3) Choose Settings'. The main content area is titled 'Site / WiFi Settings' and is divided into two sections: 'Site' and 'WiFi'.  
In the 'Site' section, there is a field for 'Install Location' containing 'POLE\_1' and a larger 'User Notes' text area.  
In the 'WiFi' section, there is a field for 'SSID Prefix' containing '650-999999-0009' and a checkbox for 'Allow changes'. Below this, the 'Effective SSID' is displayed as '650-999999-0009-POLE\_1'. A red warning message states: 'For security reasons, it is strongly recommended that the password is changed during initial setup.' There are two password fields: 'New password' and 'Confirm password', both with eye icons for visibility. A 'Please Note' at the bottom states: 'If you choose to change the password and the password is lost, the product will need to be returned to AGD to be reset.' A blue 'Next' button is located at the bottom right of the form.

**Install location** – Used to locate the detector when installed on a site. Entering an install location changes the detector’s SSID.

**You must reconnect to the new SSID** after a change is made.

E.g. Inserting POLE\_1 will change the SSID WiFi name to 650:999999-9992-POLE\_1

The use of a “space” within this field is not supported; use an underscore “\_” in its place.

**Please note:** If you have entered characters in this field, you will be notified and have to reconnect to the new SSID after clicking “next”

**User notes** – An editable field to allow engineers to store notes in the device. Max characters = 110.

**SSID prefix** – The first part of the SSID can be changed. To change, you must first tick allow changes. Default is recommended if using the default password.

**Please note:** If you have changed characters in this field, you will be notified and have to reconnect to the new SSID after clicking “next”

**Effective SSID** – Displays what SSID will be shown when searching for the new WiFi connection.

**New password/Confirm password** – To keep the default password, leave these fields blank. To change you must enter an identical password in both fields. Characters = 8 minimum, 63 maximum.

### SET-UP DEVICE USING AGD TOUCH-SETUP

#### Step 2 – SET ZONES

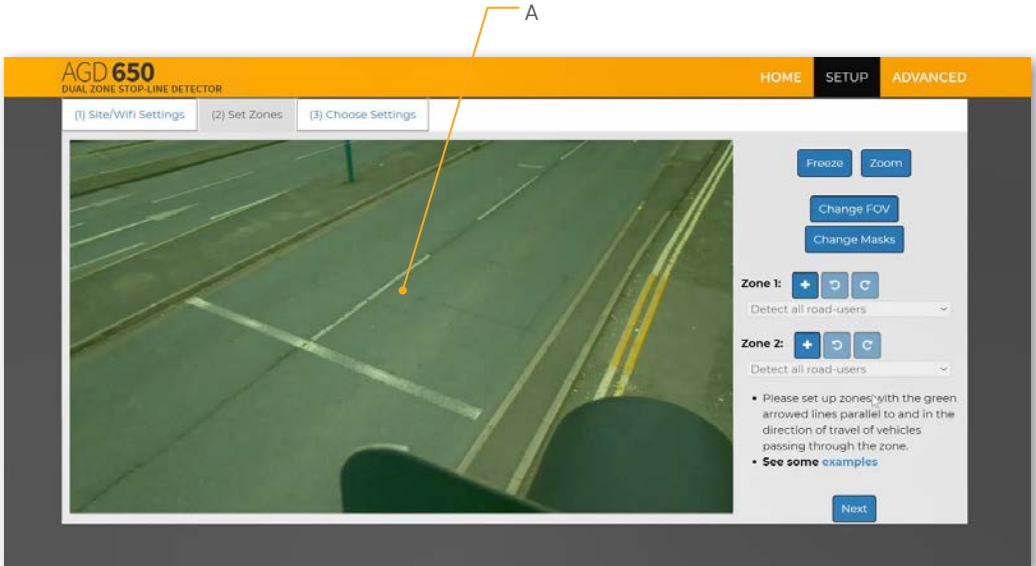

#### A – Live Traffic View

**Freeze** – Pause the live traffic view when the road is clear of traffic to aid set-up.

**Zoom** – Zoom out to extend zones off the screen.

**Change FOV** – Full field of view is recommended for most installations. A reduced field of view may be beneficial when detection zones are distant from the detector. Please contact AGD for advice.

**Change Masks** – Used to mask objects to avoid unwanted detections. See STEP 2 – SET ZONES CONTINUED section for further detail.

**Zone 1** – Detection area linked to OPTO 1 output.

Add / Undo / Redo buttons for quick set-up.

**Zone 2** – Detection area linked to OPTO 2 output.

Add / Undo / Redo buttons for quick set-up.

#### Detection Classes

**Detect all road users:** Detect all forms of vehicle and pedestrians.

**Detect 4 wheeled vehicles only:** Detect all types of vehicles with 4 wheels or more ignoring all motorbikes, cyclists, scooters and pedestrians.

**Do not detect 4 wheeled vehicles:** Only detect motorbikes, cyclists, e-scooters and pedestrians. Ignore all other vehicle types.

**Custom:** Select from available classification filter options, eg: buses

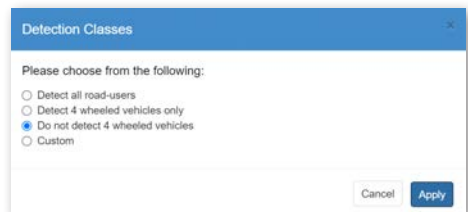

### SET-UP DEVICE USING AGD TOUCH-SETUP

#### Step 2 – SET ZONES continued

#### Change Masks

Occasionally, street furniture within the image can give rise to false detections. This can be resolved through the application of a mask. A mask is a region of the image within which the detector will not report targets. **Masks should be used sparingly.** It can be prudent to mask any foreground street furniture such as a close-up

view of the back of a signal head. Use of masks in other areas can sometimes be beneficial for resolving specific issues but should not be routinely employed. It is important to note that vehicles moving through a masked region might not be detected.

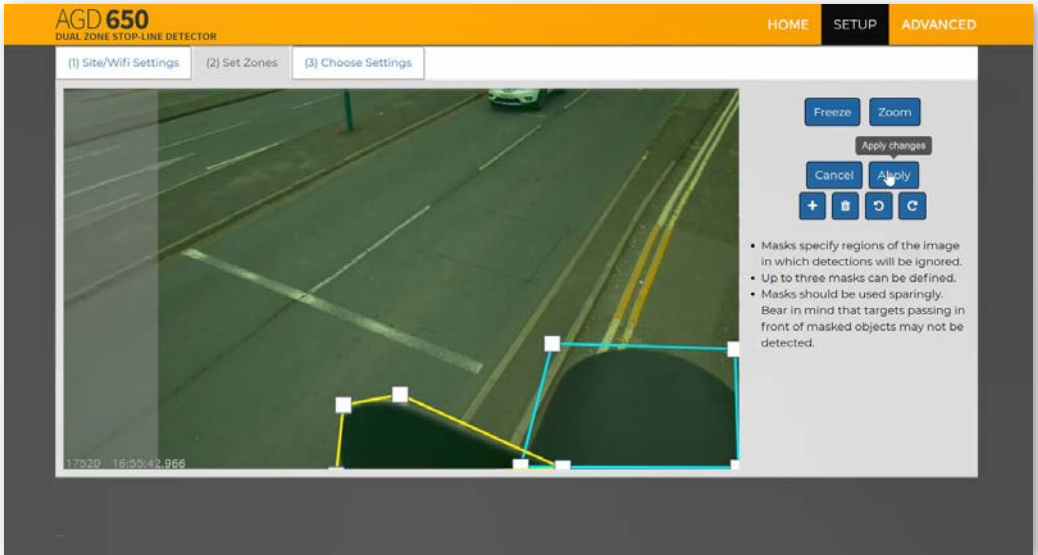

### SET-UP DEVICE USING AGD TOUCH-SETUP

Step 2 – SET ZONES continued

#### Detection Zones

Add the detection zones where required (using Zone 1 & Zone 2). The green arrows should follow the direction of traffic and be parallel with the road layout. Lane differentiation can be achieved by placing zones in the middle of each lane.

A gap between each lane is required to stop false detections of adjacent lane traffic.

Select the correct option from the drop-down list for your intended application. Each zone operates independently.

Note: If no zones have been defined, the red LED will be on and both outputs will be in the detect state.

## SET-UP DEVICE USING AGD TOUCH-SETUP

### Step 3 – CHOOSE SETTINGS

**WiFi off after** – Select how long you would like the WiFi to stay on after you have disconnected. The device will need to be power cycled to have the WiFi network viewable after the selected period.

Input range = 0 – 48h. Default = Never

**Detect LED OFF at night** – Select to disable red LED at night

**Hold time (ms)** – The amount of time the detection output is held on after a valid target leaves zone 1 or 2.

Input range = 0 – 120,000ms. Default = 0ms

**Delay before reporting demand (ms)** – The amount of time the detection output is not reported after a valid target enters zone 1 or 2.

Input range = 0 – 60,000ms. Default = 0ms

**Timeout (mins)** – The amount of time the detection output is permitted to stay ON.

Once the set timeout figure (mins) is reached the detector will go into a NON DETECT state until that vehicle has moved and another vehicle enters the detection zone

Input range = 0 – 120mins. Default = 0, OFF (never times out)

**Enter non-detect fault mode after** – If no valid targets are detected in any defined detection zone for this amount of time, the detector will revert to a permanent detect state. This state will persist until a target is detected.

**Detection threshold (%)** – The threshold value at which the detector will report a valid target. Percentage figures can be seen on the home screen when looking at the live traffic view.

Input range = 0 – 100%.

Default = 30 (recommended)

# INSTALLATION AND COMMISSIONING

## SET-UP DEVICE USING AGD TOUCH-SETUP

After configuring settings and clicking the Finish button, it is recommended to power cycle or reboot (via the ADVANCED tab) the device, reconnect and confirm that all zones and settings are configured as required.

### EXAMPLE IMAGE 1

An example of what you will see once all steps have been completed correctly.

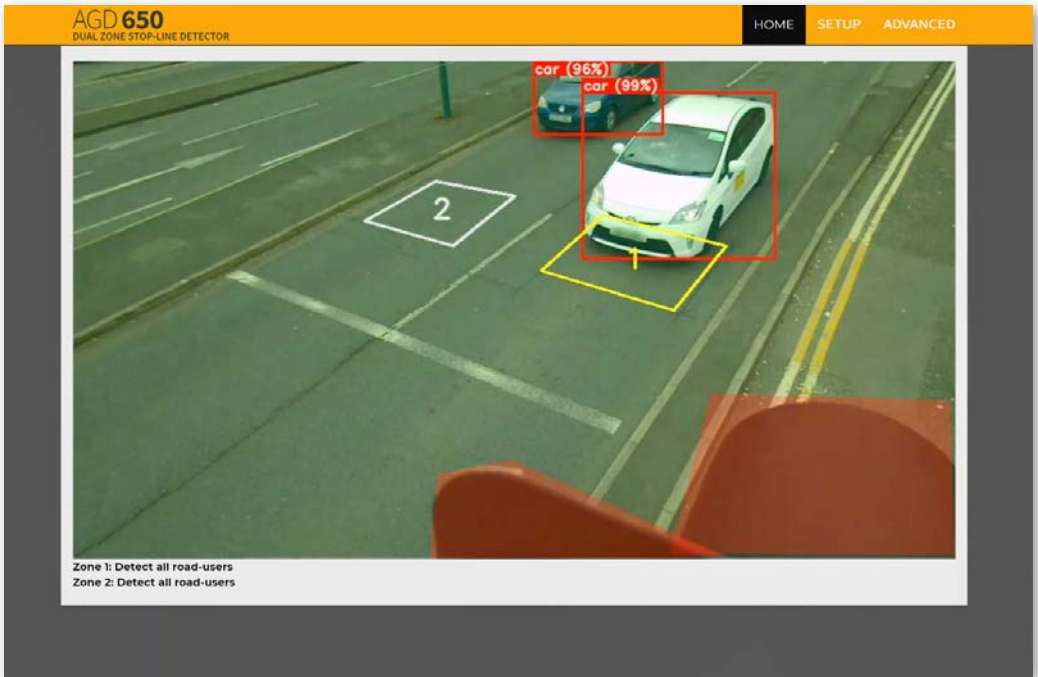

### EXAMPLE IMAGE 2

An example of what you will see once all steps have been completed correctly.

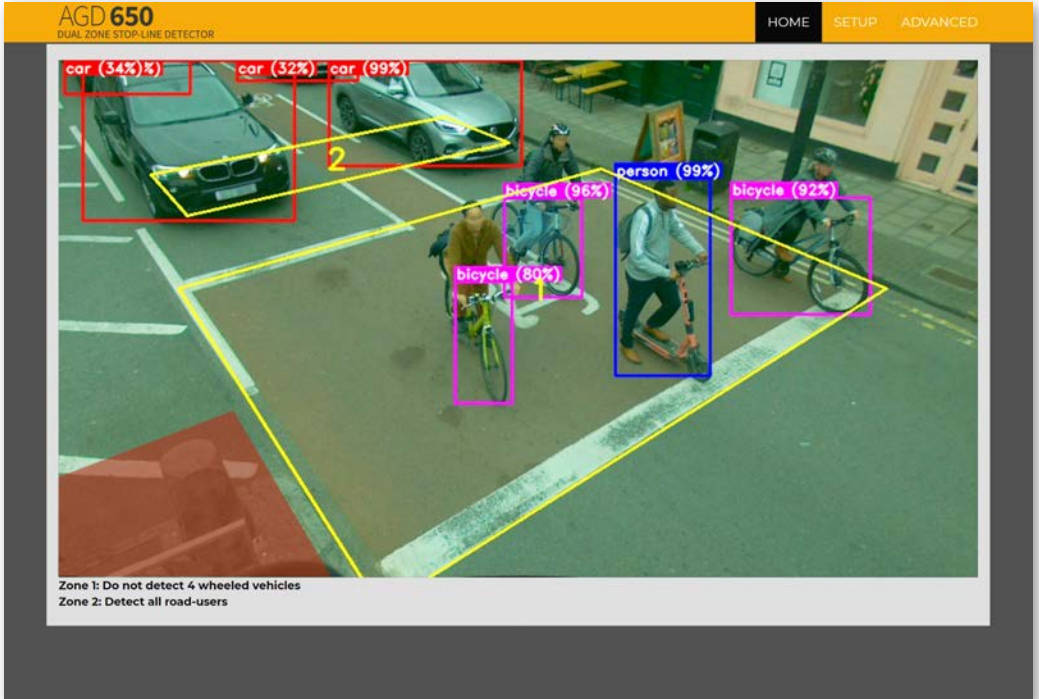

## TESTING AND COMMISSIONING

Once the Sivard System has been installed and the detection zones have been set up, monitor the traffic signals controller input board, ensuring all vehicles move through the detection zones and the appropriate detector indicator is illuminated. We recommend the system be monitored for a minimum of 15 minutes to ensure correct operations.

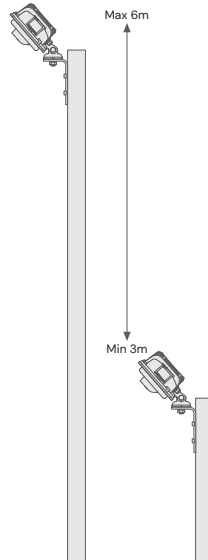

## Sivard System

Temporary loop replacement system

### STEP 2 – DETECTOR ALIGNMENT

The AGD650 Dual Zone Stop-line Detector should be mounted using the supplied hardware. The optimal mounting angle will change depending on the installation location; aiming the camera to the centre of the area of interest is a good start position. The mounting angle may need to be corrected during commissioning stage of the installation. Ensure the detector is securely fixed and the mounting nut is tight.

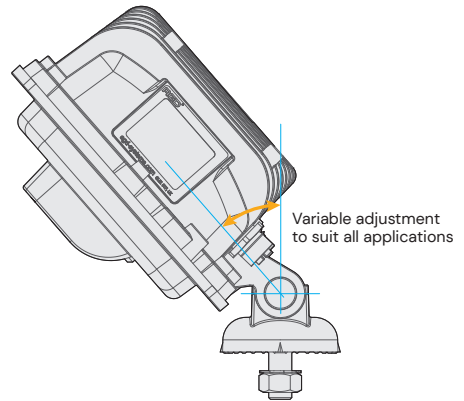

### STEP 3 – FINAL ADJUSTMENT & VERIFICATION

Confirm the detector is correctly aligned. The entire stop-line should be visible when looking at the detector's live view within the GUI. Where possible, the field of view should include at least one full vehicle length before and after each detection zone. The horizon should be out of view to reduce sun glare. Once complete, please monitor traffic to ensure zones are correctly placed.



# IMPORTANT SAFETY INFORMATION

**Sivard System**

Temporary loop replacement system

## SAFETY PRECAUTIONS

All work must be performed in accordance with company working practices, in-line with adequate risk assessments. Only skilled and instructed persons should carry out work with the product.

Experience and safety procedures in the following areas may be relevant:

- **Working with mains power**
- **Working with modern electronic/electrical equipment**
- **Working at height**
- **Working at the roadside or highways**

1. This product is compliant to the Restriction of Hazardous Substances (RoHS – European Union directive 2011/65/EU, UK Statutory Instrument 2012/3032)
2. The product must be correctly connected to the specified power supply. All connections must be made whilst the power supply is off or suitably isolated. Safety must take always take precedence and power must only be applied when deemed safe to do so.
3. No user-maintainable parts are contained within the product. Removing or opening the outer casing is deemed dangerous and will void all warranties.
4. Under no circumstances should a product suspected of damage be powered on. Internal damage may be suggested by unusual behaviour, an unusual odour or damage to the outer casing. Please contact AGD for further advice.
5. This Product is Compliant with the European Radio Equipment Directive 2014/53/EU & UK Radio Equipment Regulations 2017 (SI2017/1206) There is no restrictions of use within any EU Member state for this product. This product is Receiver Category 2.
6. Indicates compliance with all applicable Australian ACMA technical standards and associated record keeping (including testing) arrangements.

/contd

## IMPORTANT

Sivard System

Temporary loop replacement system

### SAFETY PRECAUTIONS

7. This device complies with part 15 of the FCC Rules and contains licence-exempt transmitter(s)/ receiver(s) that comply with Innovation, Science and Economic Development Canada's licence-exempt RSS(s).

• Operation is subject to the following two conditions:

(1) This device may not cause harmful interference, and

(2) This device must accept any interference received, including interference that may cause undesired operation

Le présent appareil est conforme aux CNR d'ISDE Canada applicables aux appareils radio exempts de licence.

L'exploitation est autorisée aux deux conditions suivantes : (1) l'appareil ne doit pas produire de brouillage, et (2) l'appareil doit accepter tout brouillage radioélectrique subi, même si le brouillage est susceptible d'en compromettre le fonctionnement.

- This equipment complies with FCC radiation exposure limits set forth for an uncontrolled environment. End users must follow the specific operating instructions for satisfying RF exposure compliance such that the module should not be installed in equipment intended to be used within 20cm of the body.
- The transmitter must not be co-located or operating in conjunction with any other antenna or transmitter.
- Changes or modifications not expressly approved by AGD Systems Pty Ltd could void the user's authority to operate the equipment.



# DISCLAIMER

While we (AGD Systems Pty Ltd) endeavour to keep the information in this manual correct at the time of download or print, we make no representations or warranties of any kind, express or implied, about the completeness, accuracy, reliability, suitability or availability with respect to the information, products, services, or related graphics contained herein for any purpose.

Any reliance you place on such information is therefore strictly at your own risk. In no event will we be liable for any loss or damage including without limitation, indirect or consequential loss or damage, or any loss or damage whatsoever arising from loss of data or profits arising out of, or in connection with, the use of this manual.

## Warranty

All AGD products are covered by a 12 month return to factory warranty. Products falling outside this period may be returned to AGD Systems Pty Ltd for: evaluation, repair, update or re-calibration, any of which may be chargeable.

CREATED
Issue 30 April 2025

**AGD**<sup>®</sup> | SAFER  
GREENER  
MORE EFFICIENT  
AUSTRALASIA

**AGD Systems Pty Ltd**

U 17/15 Valediction Road  
Kings Park, NSW 2148

**Tel:** (02) 9653 9934

**Email:** [admin@agd-systems.com.au](mailto:admin@agd-systems.com.au)

**Web:** [www.agd-systems.com.au](http://www.agd-systems.com.au)